

# FJ

# Integral Supply

## INTEGRAL SOLUTIONS

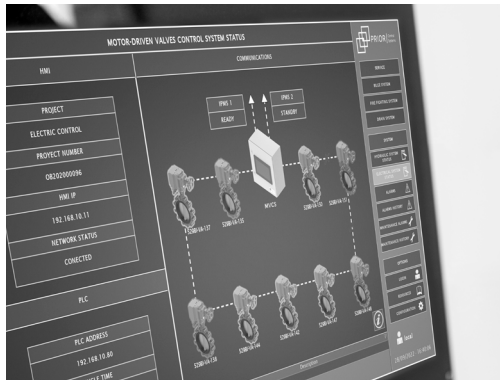

# FJ | INTEGRAL SUPPLY

**F**or 50 years, Fernández Jove has been a synonym of quality and excellent service in the shipbuilding sector. The company has a highly qualified and committed staff who is always ready to provide the best solutions with the objective of satisfying the needs of each client.

With a broad experience in turnkey solutions, FJ offers a complete package of engineering, documentation, manufacturing, integration, certification, commissioning and life cycle support.

The company's large portfolio of products and services for the shipbuilding industry includes the following:

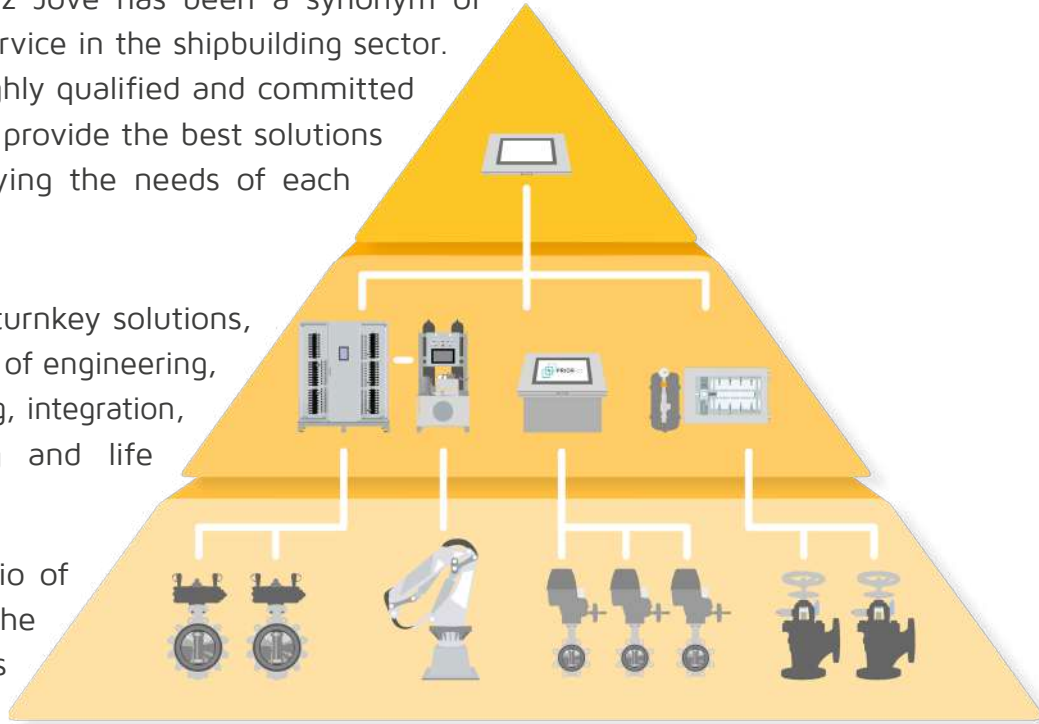

- Specific and customized solutions for motor operated valves and quick closing valves systems
- Pneumatic and hydraulic systems for handling equipment
- Life cycle support (acquisition, complete documentation, logistics, product lifecycle, technical support, etc.) along all the phases of the project



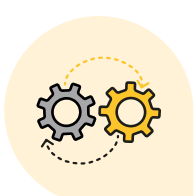
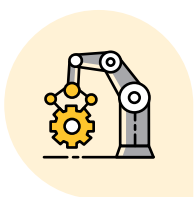

# PROJECT MANAGEMENT

**FJ**'s project management team develops customized turnkey solutions for marine valves, motorized valves systems, quick closing valves systems, and hydraulic and pneumatic equipment.

Developing turnkey projects implies taking responsibility of the full scope of the process. From its very beginning, the company is able to carry out the functional and detail engineering, followed by the manufacturing and supply. FJ works alongside shipyards and auxiliary companies to implement the installation and commissioning properly and offers a full life cycle support after the shipbuilding processes are completed.

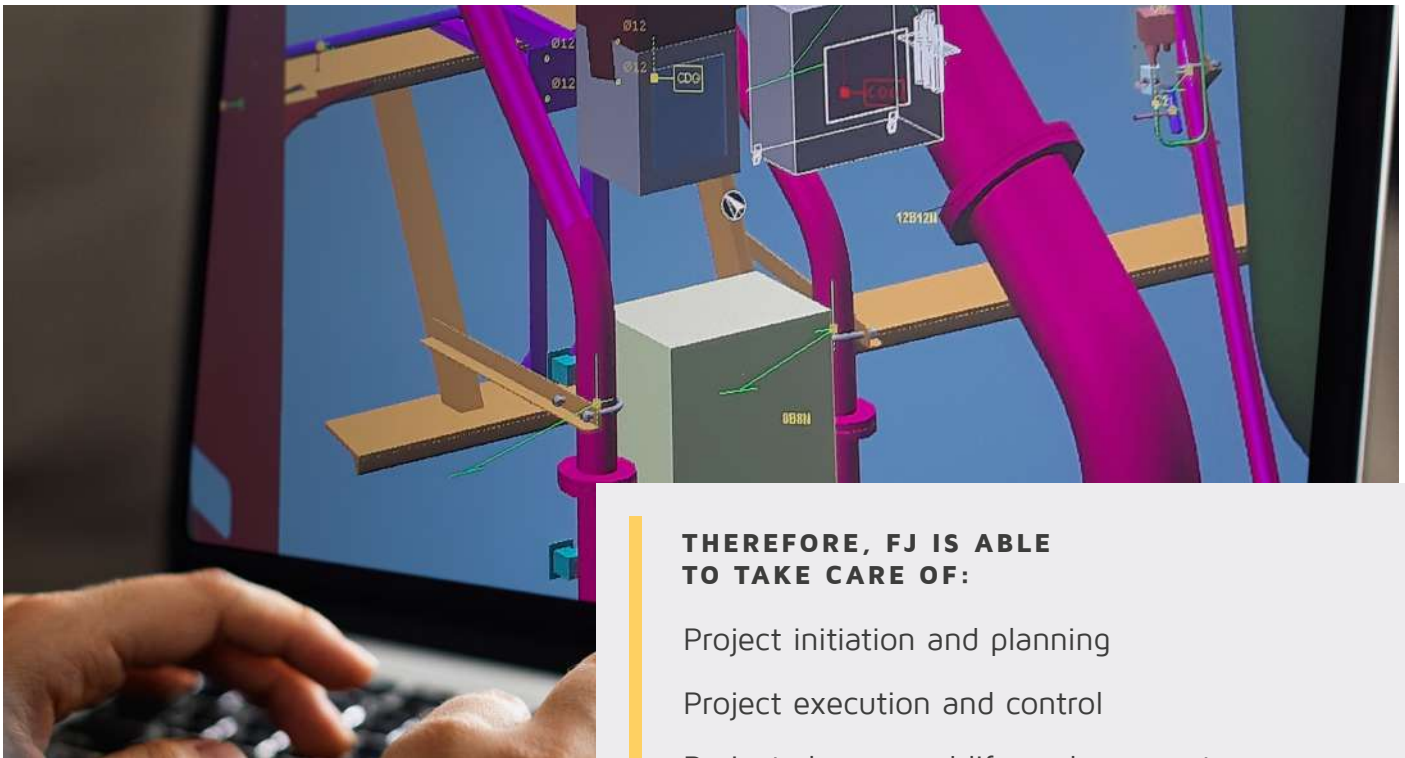

**THEREFORE, FJ IS ABLE TO TAKE CARE OF:**

- Project initiation and planning
- Project execution and control
- Project closure and life cycle support

**FJ'S PRIORITY IS TO OFFER A FULL CUSTOMER-FOCUSED APPROACH. WITH THIS PURPOSE, THE ENGINEERING TEAM WORKS LOOKING FOR THE BEST SOLUTIONS AND MANAGE EVERY PROJECT FROM SCRATCH, SEEKING TO ACCOMPLISH EXCELLENCE AND A FULLY OPERATIONAL SYSTEM.**

# ENGINEERING

The company counts with a highly specialized technical staff in the field of valves, hydraulics, pneumatics and process automation. This enables FJ to carry out personalized solutions according to the needs of each project.

FJ's high degree of flexibility allows developing from basic engineering to turnkey solutions.

## CONCEPTUAL AND BASIC ENGINEERING

- Selection and specification of instrumentation and valves
- Technical specifications of systems and equipment
- Engineering calculations, preliminary studies and technical reports
- Definition and design of control and automation systems

## DETAIL ENGINEERING

- Construction and assembly works plans
- 3D modelling, 2D extraction and shape optimization
- Diagrams and calculations
- Electrical and automation wiring diagrams

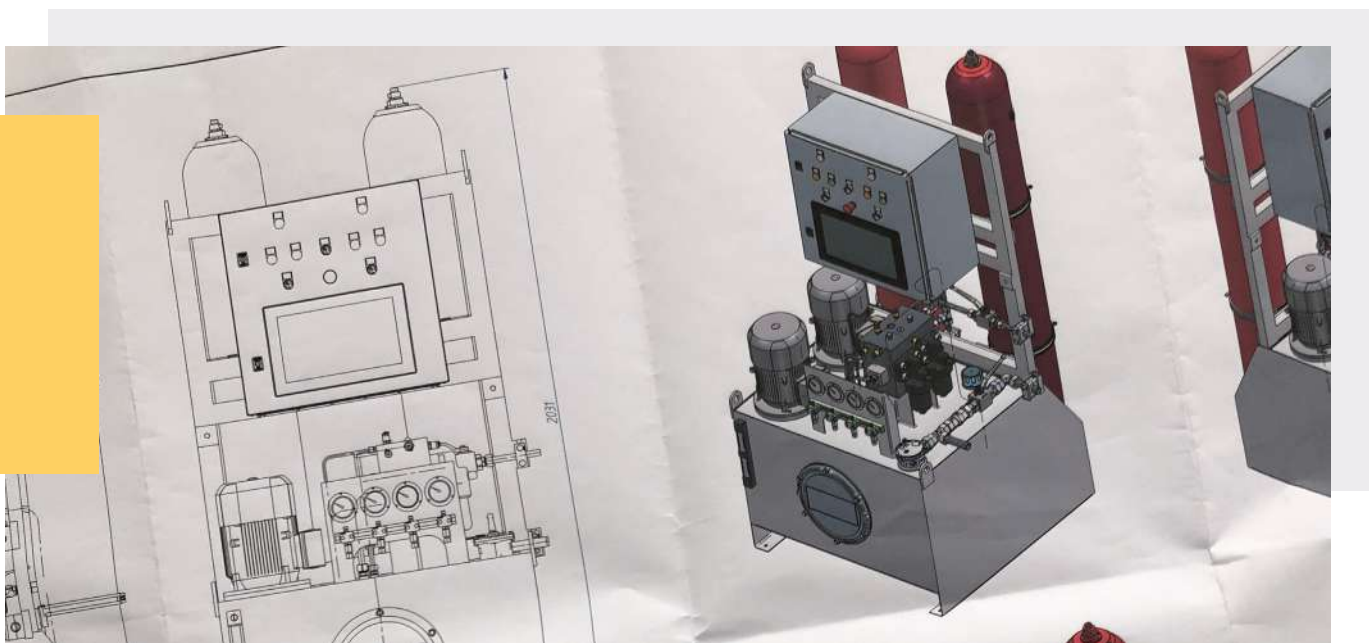

# DOCUMENTATION

**FJ** is able to provide the necessary documentation packages during the development of a project:

## MANAGEMENT DOCUMENTATION

Normally needed from the beginning, management documentation includes quality and configuration plans, risk management procedures and planning of activities.

## QUALITY DOCUMENTATION

All different types of certificates which are demanded for the development of the project, such as class or material certificates, are included in this package.

## VERIFICATION AND VALIDATION DOCUMENTATION

This documentation package includes compliance and traceability matrix, test procedures and reports, and all documents related to requirements verification and validation.

## TECHNICAL DOCUMENTATION

This package contains all the information related to the technical details of the equipment to be supplied, including drawings, technical and functional descriptions, reports on calculations, electrical and automation documentation, etc.

## LOGISTICS DOCUMENTATION

Developed to assist the final user during the life cycle of the equipment, including installation, operation and maintenance.

Operation manuals, maintenance instructions, lists of recommended spare parts and obsolescence documentation are included.

## SAFETY DOCUMENTATION

Failure analysis (such as FMECA), hazard logs, safety considerations in design, human factors and related information are included in the safety documentation package.

# MANUFACTURING



## MARINE VALVES

High quality SAVAL valves for the marine sector, including different types such as globe, ball, gate, butterfly, etc.



## MOTOR-DRIVEN VALVES

Valve remote control systems including valves, actuators (electric, hydraulic or pneumatic) with the monitoring and control system.



## QUICK CLOSING VALVES

Quick closing valves with remote control for the emergency closing of fluid lines in case of leak or fire.



## REMOTE CONTROL SYSTEMS

PRIOR control system, developed for the monitoring and remote operation of valves and other equipment in different vessel services.

## MARINE VALVES MANUFACTURING

**W**ith the brand SAVAL, FJ has positioned itself as one of the leading European manufacturers of high-quality marine valves. The company is committed to providing support for many navies and shipowners around the world.

SAVAL valves are 100% European manufactured, which guarantees an optimum performance and a high durability of the product. FJ's manufacturing system offers complete traceability, from the origin of the valve's production process to its final dispatch.

FJ's production capacity is committed to flexibility and service by and for the customer as the main element of its internal planning, always focused on solving critical situations that may arise.



### SAVAL MANUFACTURES THE FOLLOWING TYPE OF VALVES :

- Globe valves
- Gate valves
- Butterfly valves
- Ball valves
- Check valves
- Safety valves
- Quick closing valves



## MOTOR-DRIVEN VALVES MANUFACTURING

The motor-driven valves system is composed of valves, actuators and control panels. It makes it possible to remotely open and close the desired ones in order to redirect the flow of the fluid lines, such as ballast, bilge or fuel-oil systems, without the need of doing it locally.

There are several possible combinations and types of actuated valves, with different valve models and different actuators. The selection of the actuator depends on different factors and there are mainly three different types:

- Electrical actuators
- Hydraulic actuators
- Pneumatic actuators

The control panels contain a set of electrical elements, hardware and software that allow the remote operation of the valves. Depending on the type of actuators used it will also be necessary to install the proper hydraulic or pneumatic equipment. The control panels communicate with the Integrated Automation Systems (IAS) to transmit the signals and alarms desired.

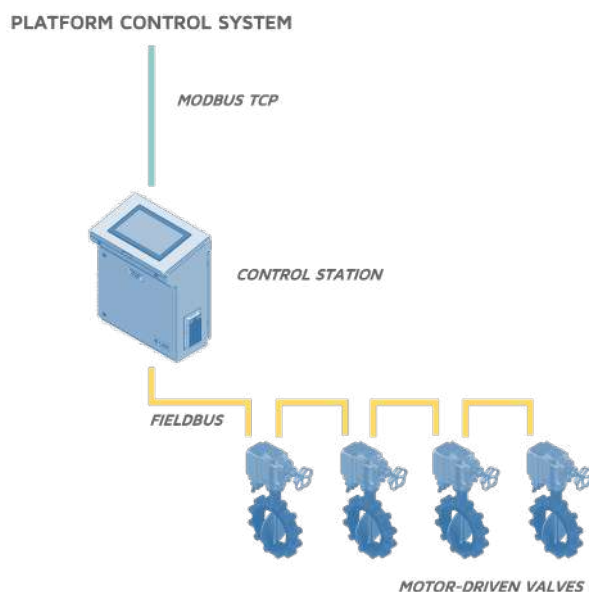

FJ offers the complete scope of work of the system. This includes the development of engineering, starting with the project information, the manufacture of the control panels, the manufacture of SAVAL valves, the integration of the actuators, and complementing all the above with logistics and technical documentation packages, as well as technical support during installation, commissioning, and life cycle.

## QUICK CLOSING VALVES MANUFACTURING

**Q**uick closing valves system allows the remote and instantaneous shutoff of fluid lines. These valves are normally open, and their functionality is to interrupt the passage of fluid in emergency situations (such as leaks or fire).

The system is composed of valves and control panels. The valves are installed in potential flammable liquid lines (fuel, oils, etc.) and they are generally used in the outlet of tanks. The control panels are composed by the necessary electrical and pneumatic or hydraulic elements to ensure the remote closing of the valves and transmit signals and alarms to the IAS. The control panel is installed in a safe area.



### THE REMOTE CONTROL OF THE QUICK CLOSING VALVES CAN BE PERFORMED IN THREE POSSIBLE WAYS:

- Hydraulic control
- Pneumatic control
- Electro-pneumatic control

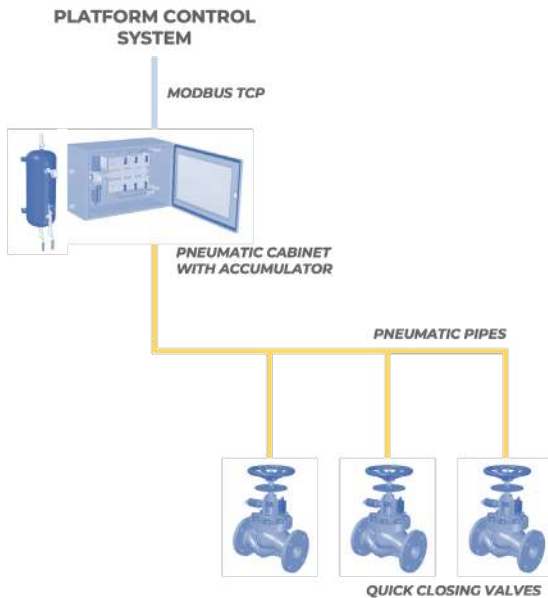

FJ offers the complete scope of work of the quick closing system. This includes the development of engineering, starting with the project information, the manufacture of the control panels, the manufacture of SAVAL valves, and complementing all the above with logistics and technical documentation packages, as well as technical support during installation, commissioning, and life cycle.

## REMOTE CONTROL SYSTEMS MANUFACTURING

**P**RIOR is a system developed by FJ for automation and remote control of valves in fluid systems. It is a system specifically designed for the naval sector, which provides a global vision of the state of the equipment, offering the operator a complete control interface from one or several points of the installation. Thanks to its modular and flexible concept, PRIOR adapts to the specific needs of each project.

PRIOR connects to different equipment and systems (both its own and those of others) using the most common universal communication protocols (Modbus, Profibus, etc.). This makes it possible to take control from a superior entity such as the vessel platform management system.



PRIOR has different modules for predefined applications, which can be combined to offer a complete control system that integrates different types of equipment.

The system is capable of handling and managing different types of signals (analogue, digital, remote commands, etc.), as well as integrating automatism that facilitate control by the user.

PRIOR is a modular and scalable system, fully adaptable to the needs of each project. This allows customizing the control and monitoring options as required in each case, integrating different types of equipment and systems.



# CERTIFICATIONS

**FJ** is able to manage the certification of the equipment supplied in the project according to the specifications of the selected classification of society. The company uses IACS rules for the design of all the systems, using them as a reference in every project.

FJ's longstanding commitment in the sector allows the technical and quality departments to have a wide experience working with the most important classifications societies.

FJ works hand to hand with the inspectors from the very beginning of the design phases until the very end of the onboard commissioning, helping the customers to achieve their goals with the final users.



MIL-S-901D  
MIL-STD-798

All the equipment manufactured by FJ undergo rigorous quality tests that guarantee the product and the reliability of its performance.

The company works with Type Approved components for every system designed, and their main products have Type Approval Certificates by several IACS companies.

FJ puts great emphasis on its quality control system, being approved according to the standard UNE-EN-ISO 9001.

# COMMISSIONING

**FJ**'s technical team is in charge of the correct commissioning of every supplied equipment, making sure that the client receives fully operational systems. FAT tests are always performed before the delivery of the equipment, according to the procedures previously approved by the customer and the classification society.

Once onboard, HAT and SAT procedures are followed to properly perform the commissioning of the equipment, making sure that everything is operating correctly on completion.

Factory tests

Onboard commissioning

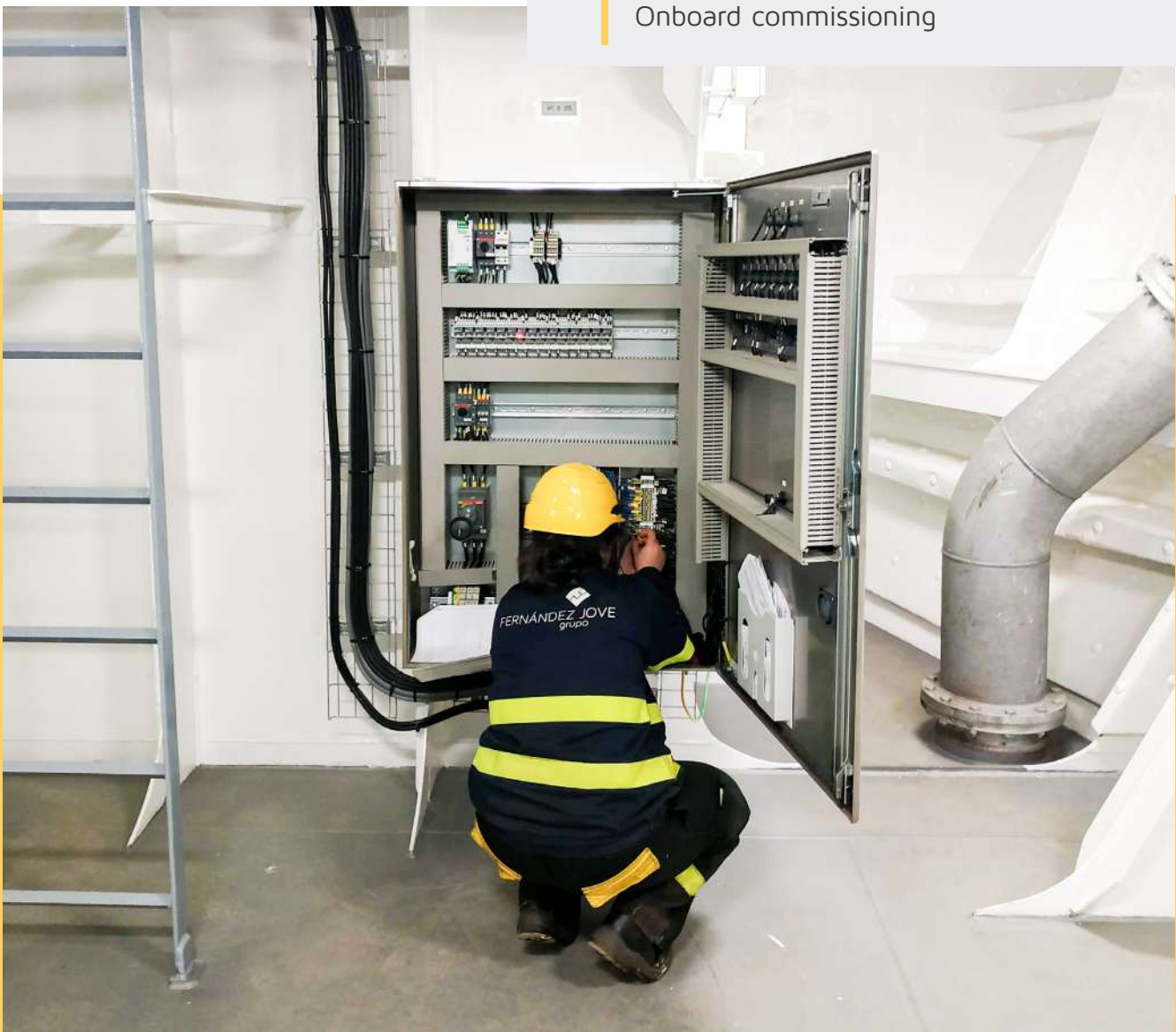

# LIFE CYCLE SUPPORT

The company is aware that the project is not finished with the commissioning, and the most critical situations arise afterwards due to unexpected stops, maintenance, and breakdowns. It is for this reason that FJ focuses on assisting the client throughout the useful life of the equipment/systems, guaranteeing support during its life cycle.

This approach is applied to the projects from the beginning, creating technical and logistics documentation, spare parts lists, detailed plans, and diagrams which simplify the tasks of corrective, preventive and predictive maintenance.

Moreover, if requested, FJ provides advanced technical training for the crew and the maintainers about the supplied systems. This training can be carried out on board, on the client facilities or in FJ's offices.



- Training programs
- Obsolescence management
- Technical support
- Codification and documentation support
- Inspections and troubleshooting
- International repair centres





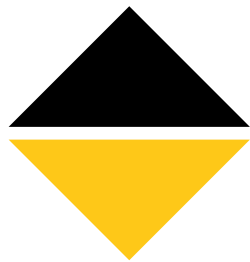

FJ



Integral  
Supply

**FJ** | Integral Supply

[WWW.FERNANDEZJOVE.COM](http://WWW.FERNANDEZJOVE.COM)

[ventasfj@fjove.com](mailto:ventasfj@fjove.com)

 **FERNÁNDEZ JOVE**<sup>®</sup>  
group